

KOENIG EXPANDER® SETTING TOOLS

Series MB/CV Air Hammer

North American Tool Option

Material:
Tool Steel, Heat Treated,
Hardness Approx. HRC 50

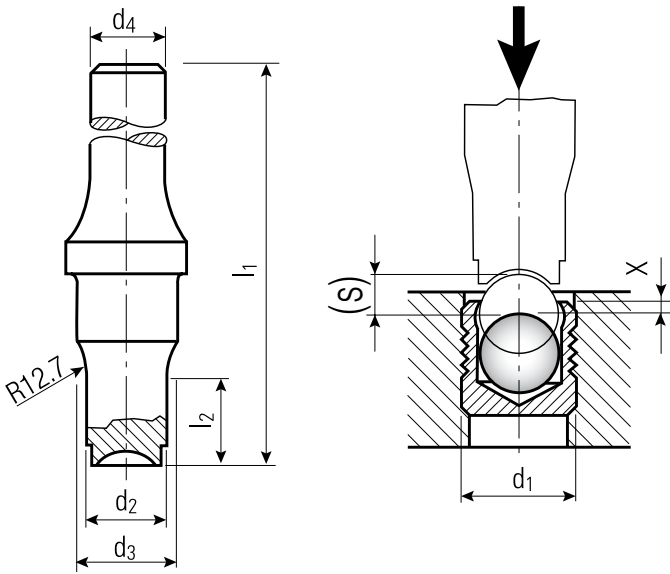

Part Number	d ₁ Expander	d ₃ ±0.12	d ₄ (AH only)	l ₁	d ₂	l ₂	x ±0.10	(s) ~ Ref.	Weight in gram/pcs.
AH-MBM-030	MB/CV XXX-030	12.7	10.2	101.6	2.8	7.6	0.2	1.0	83
AH-MBM-040	MB/CV XXX-040	12.7	10.2	101.6	3.8	7.6	0.2	1.4	84
AH-MBM-050	MB/CV XXX-050	12.7	10.2	101.6	4.8	12.7	0.2	1.9	81
AH-MBM-060	MB/CV XXX-060	12.7	10.2	101.6	5.8	15.2	0.2	2.3	81
AH-MBM-070	MB/CV XXX-070	12.7	10.2	101.6	6.8	20.3	0.2	2.8	79
AH-MBM-080	MB/CV XXX-080	12.7	10.2	101.6	7.8	33.0	0.2	3.4	74
AH-MBM-090	MB/CV XXX-090	12.7	10.2	101.6	8.8	33.0	0.2	3.7	78
AH-MBM-100	MB/CV XXX-100	12.7	10.2	101.6	9.8	38.1	0.2	4.2	80
AH-MBM-120	MB/CV XXX-120	12.7	10.2	101.6	11.7	38.1	0.2	5.1	91
AH-MBM-140	MB/CV XXX-140	12.7	10.2	101.6	13.7	-	0.2	5.9	98
AH-MBM-160	MB/CV XXX-160	12.7	10.2	101.6	15.7	-	0.2	6.4	101
AH-MBM-180	MB/CV XXX-180	12.7	10.2	101.6	17.7	-	0.2	7.2	105
AH-MBM-200	MB/CV XXX-200	12.7	10.2	101.6	19.7	-	0.2	8.4	110
AH-MBM-220	MB/CV XXX-220	12.7	10.2	101.6	21.7	-	0.2	9.5	116

Dimensions in millimeters

RECOMMENDED SETTING EQUIPMENT FOR SERIES MB/CV

North American customers please contact application engineering for ExHammer recommendations.