

KOENIG EXPANDER® SETTING TOOLS

Series MB/CV Short Air Hammer

North American Tool Option

Material:
Tool Steel, Heat Treated,
Hardness Approx. HRC 50

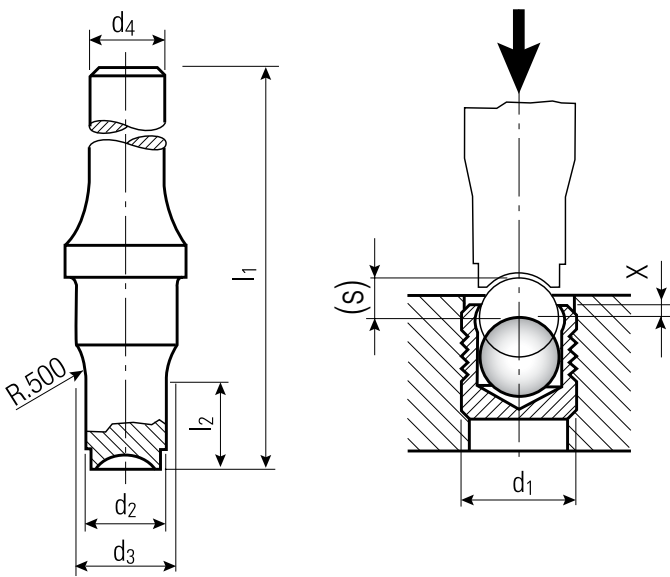

Part Number	d ₁ Expander	d ₃ ±0.005	d ₄	l ₁	d ₂	l ₂	x ±0.004	(s) ~ Ref.	Weight in gram/pcs.
AH-CVI-125	CV XXX-125S	0.5	0.401	4.0	0.111	0.3	0.007	0.042	83
AH-CVI-156-S	CV XXX-156S	0.5	0.401	4.0	0.142	0.3	0.000	0.040	84
AH-CVI-187	CV XXX-187S	0.5	0.401	4.0	0.173	0.4	0.010	0.066	83
AH-CVI-218	CV XXX-218S	0.5	0.401	4.0	0.204	0.5	0.010	0.063	82
AH-CVI-250	CV XXX-250S	0.5	0.401	4.0	0.236	0.6	0.010	0.083	81
AH-CVI-281-S	CV XXX-281S	0.5	0.401	4.0	0.267	0.8	0.000	0.091	79
AH-CVI-312	CV XXX-312S	0.5	0.401	4.0	0.298	1.3	0.010	0.107	73
AH-CVI-343	CV XXX-343S	0.5	0.401	4.0	0.329	1.3	0.010	0.118	76
AH-CVI-406	CV XXX-406S	0.5	0.401	4.0	0.329	1.5	0.010	0.143	81

Dimensions in Inches

RECOMMENDED SETTING EQUIPMENT FOR SERIES MB/CV

North American customers please contact application engineering for ExHammer recommendations.