

KOENIG CHECK VALVE® SETTING TOOL

Series BF and BR

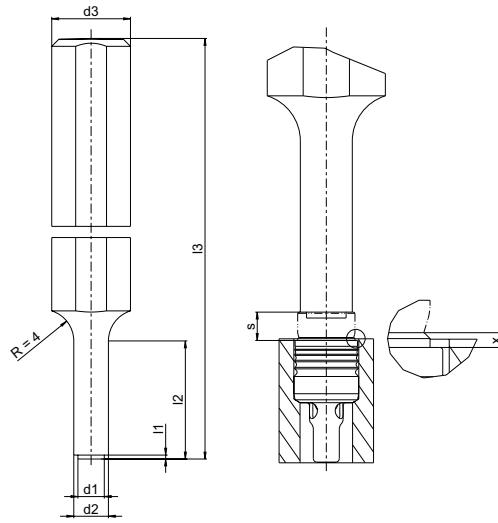

Part Number	Part Name	$d_1^{\pm 0.05}$	$d_2^{\pm 0.05}$	$d_3 \text{ h9}$	l_1	l_2	l_3	x	(s)
ST – 055 – 0280	Setting Tool 5.5	2.80	4.40	10.0	$0.5^{+0.05}$	15	100	$0^{+0.25}$	2.4
ST – 055 – 0335	Setting Tool 5.5	3.35	4.40	10.0	$0.5^{+0.05}$	15	100	$0^{+0.25}$	2.4
ST – 080 – 0380	Setting Tool 8.0	3.80	6.20	10.0	$2.4^{\pm 0.10}$	20	100	$0^{\pm 0.15}$	4.0

Dimensions in millimeters

RECOMMENDED SETTING EQUIPMENT FOR SERIES BF AND BR

EXPRESS 3000

Hydropneumatic Table Press

See page 64 for more information