

GALVANIC CORROSION

In choosing a KOENIG EXPANDER® you must consider that the material of the sealing plug and the material of the production piece can show different electrical potentials. In the presence of an electrolyte (e.g. 5% water-NaCl solution), this potential difference causes electrochemical attack on the least noble of the metals in contact – galvanic corrosion. In this case, either the base material or its surface protection will become the anode and will be transferred to the pure metal of the cathode. The corrosion speed or the current density will be determined by the relative surface area or volume of the anode and cathode as illustrated below.

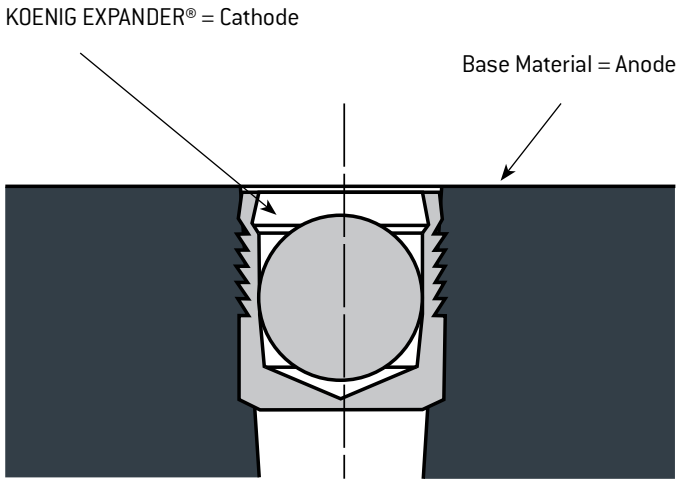

Large Anode Area —> Low Current Density at the Anode —> **Slow Corrosion**

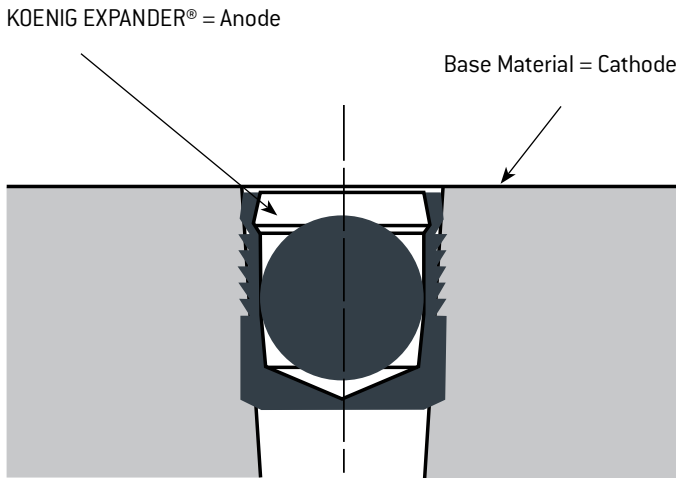

Small Anode Area —> High Current Density at the Anode —> **Fast Corrosion**

GALVANIC CORROSION

EFFECT OF GALVANIC CORROSION

The following table shows the expected galvanic corrosion behavior of KOENIG EXPANDER® plugs in common base materials allowing for the relative surface areas of both metals, which influences the speed of corrosion.

Installation Material	Series									
	MB 600	MB 700	MB 850	CV 173	CV 588	SK/SKC	LK 600	LK 950	BF/BR	RE
Steel, Carbon/Low Alloy, Plain										
Steel, Carbon/Low, Zn Plated, Chromate										
Steel, Carbon/Low Alloy, Phosphatized										
Nitrided or Case Hardening Steel	Behavior Depends on the Method Used									
Stainless Steel, X8CrNiS18-9, 1.4305, ANSI 303										
Stainless Steel, X12CrS13, 1.4005, ANSI 416										
Cast Iron, EN 1561, Plain										
Cast Iron, EN 1561, Zn Plated, Chromate										
Cast Iron, EN 1561, Phosphatized										
Ductile Cast Iron, EN 1563, Plain										
Ductile Cast Iron, EN 1563, Zn Plated, Chromate										
Ductile Cast Iron, EN 1563, Phosphatized										
AlMg1SiCu EN AW-6061										
AlMgSiPb EN AW-6062										
AlCu4Mg1 EN AW-2024										
AlZnMgCu1,5 EN AW-7075										
G-AlSi7Mg A-Norm 356										
G-AlSi9Mg										
G-AlSi10Mg										

= Accelerated
 = Not Accelerated
 = Slightly Accelerated

Key to the galvanic corrosion behavior of KOENIG EXPANDER® plugs in the presence of an electrolytic medium installed in base materials per the above table.

Suggestions to Prevent Galvanic Corrosion

- Choose materials with no or low potential difference.
- Use corrosion reducing designs, i.e. if possible prevent the accumulation of fluids on the outer surface of the workpiece.
- By using suitable surface coatings, corrosion attack can be considerably reduced.

Salt spray testing per DIN EN ISO 9227 is available upon request