

# KOENIG CHECK VALVE® Series BR 5.5mm Reverse

## REVERSE FLOW CHECK VALVE

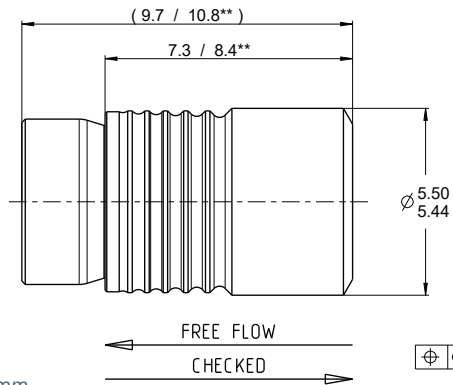

## INSTALLATION HOLE

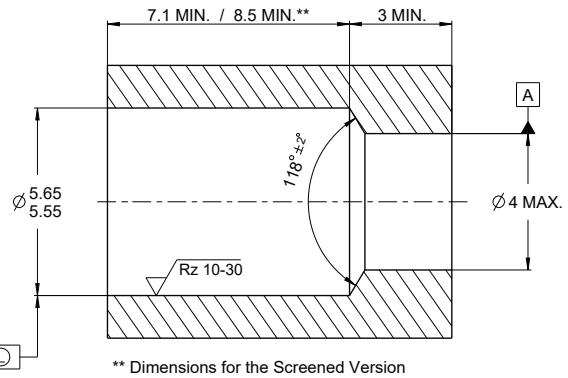

Dimensions in mm

### CHECK VALVE REVERSE FLOW - UNSCREENED

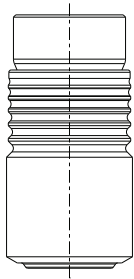

Part Number	Cracking Pressure (bar)
BRAA055U000	0.00 (no spring)
BRAA055U014	0.14 (± 0.05)
BRAA055U025	0.25 (± 0.10)
BRAA055U040	0.40 (± 0.30)
BRAA055U050	0.50 (± 0.30)
BRAA055U100	1.00 (± 0.30)
BRAA055U200	2.00 (± 0.30)

### CHECK VALVE REVERSE FLOW - SCREENED

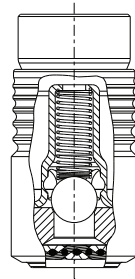

Part Number	Cracking Pressure (bar)
BRAA055S000	0.00 (no spring)
BRAA055S014	0.14 (± 0.05)
BRAA055S025	0.25 (± 0.10)
BRAA055S040	0.40 (± 0.30)
BRAA055S050	0.50 (± 0.30)
BRAA055S100	1.00 (± 0.30)
BRAA055S200	2.00 (± 0.30)

3D DATA: [www.sfckoenig.com](http://www.sfckoenig.com)

### CHECK VALVE FLOW CURVE - UNSCREENED

BRAA055U014; T=50°C; Hydraulic Oil HLP46

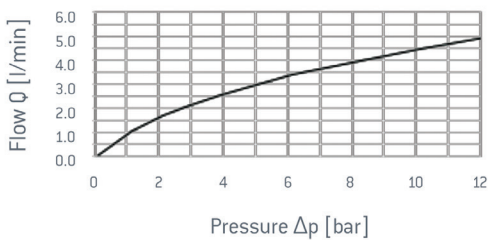

### CHECK VALVE FLOW CURVE - SCREENED

BRAA055S014; T=50°C; Hydraulic Oil HLP46

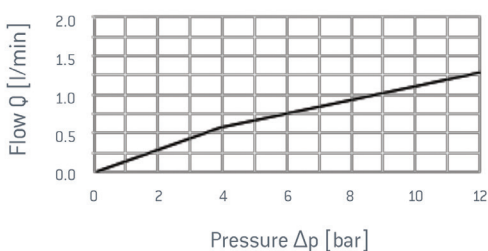

### PERFORMANCE

Max. Installation Force	6200 N
Max. Working Pressure in Check Direction	280 bar
Max. Working Pressure in Flow Direction	40 bar
Max. Leakage on Air	20 sccm/min. @ 1.72 bar
Max. Leakage on Hydraulic Fluid (HLP46)	1 drop / min.
Cycle Test on Hydraulic Fluid (HLP46)	1 Mio. Cycles, 5 Hz, 6 bar, 50°C
Screen Size	125 Microns Absolute
Material of Test Body	EN-GJS-600-3

### MATERIALS

Sleeve	1.4305 / AISI 303
Pin	1.4021 / AISI 420A
Cage	1.4305 / AISI 303
Spring	1.4310 / AISI 301
Ball	1.3541 / AISI 420C
Screen	1.4401 / AISI 316L

### SETTING TOOL

Check Valve Forward Flow – Unscreened	ST – 055 – 0335
Check Valve Forward Flow – Screened	ST – 055 – 0335